

ARCHITECTS APPROVAL

CONTRACTORS APPROVAL

MAXIMUM DIMENSIONS

RATING	APPLICATION	MAX. AREA OF GLASS SQ INCH	MAX. WIDTH INCH
60 MIN	HORIZONTAL	3481	88 1/2"

REVISIONS	DESCRIPTION	DATE	BY
△	--	--	

PROJECT NAME

CUSTOMER NAME

DRAWN BY	PAGE No.
CHECK'D BY:	P1
SCALE	PROJECT #
DATE	INSTALLER

Greenlite Glass Systems
Unit 55 - 2495 Davies Ave
Port Coquitlam, BC V3C 0B2

Phone: 778.285.8530
Fax: 778.285.8520

USA Patent No: 7 694 475 | Canada Patent No: 2 440 439

COPYRIGHT 2008 GREENLITE GLASS SYSTEMS Inc.

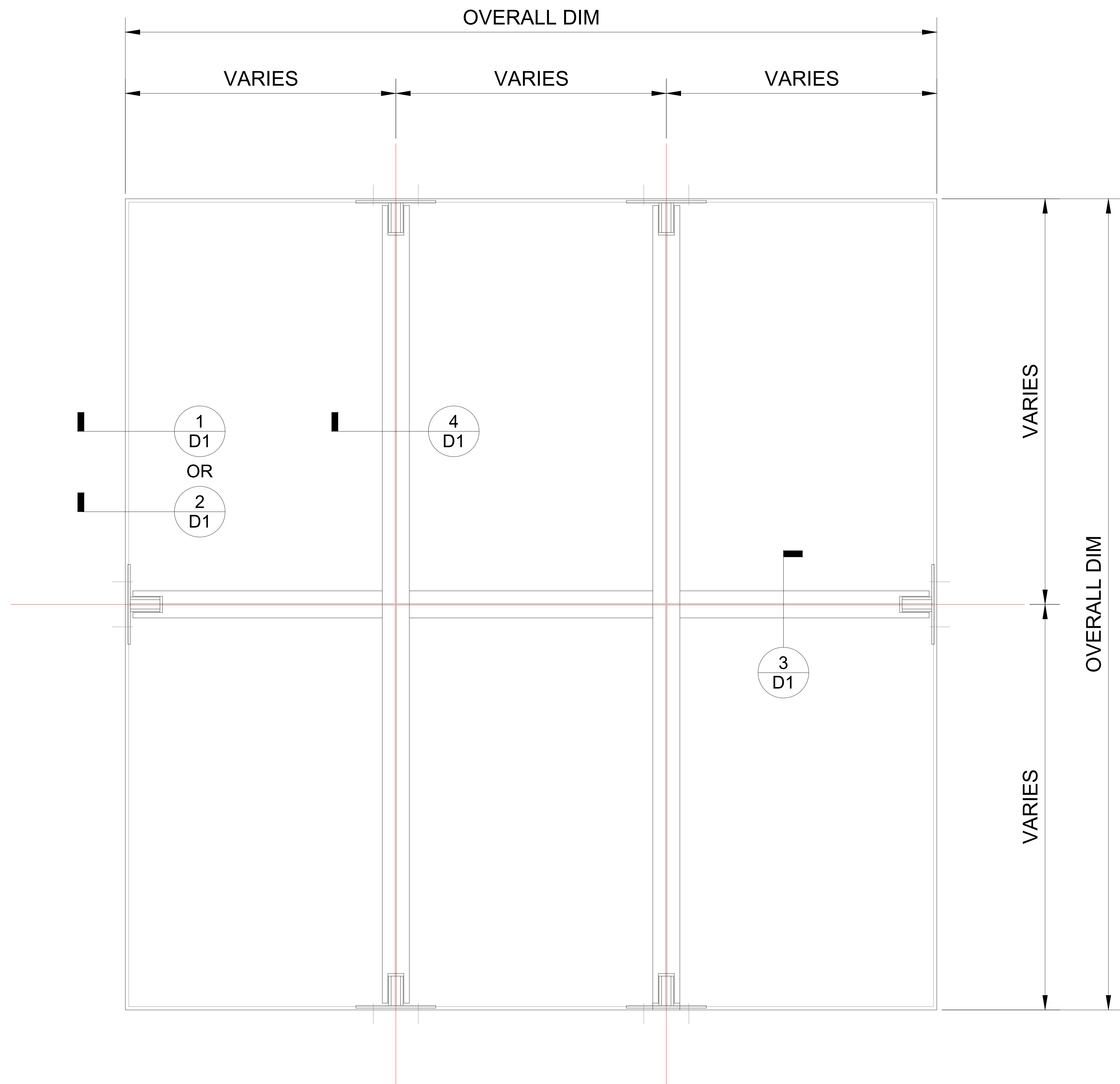

1 PLAN VIEW (EXTERIOR)
SCALE: 1/2" = 1"
GREENLITE GLASS (INTERIOR)

ARCHITECTS APPROVAL

CONTRACTORS APPROVAL

MAXIMUM DIMENSIONS

APPLICATION	MAX. LENGTH INCH	MAX. WIDTH INCH
HORIZONTAL	202"	84"

REVISIONS	DESCRIPTION	DATE	BY
△	--	--	

PROJECT NAME

CUSTOMER NAME

DRAWN BY	PAGE No.
CHK'D BY:	D1
SCALE	PROJECT #
DATE	INSTALLER

 Greenlite Glass Systems
 Unit 55 - 2495 Davies Ave
 Port Coquitlam, BC V3C 0B2

 Phone: 778.285.8530
 Fax: 778.285.8520

USA Patent No: 7 694 475 | Canada Patent No: 2 440 439

COPYRIGHT 2008 GREENLITE GLASS SYSTEMS Inc.

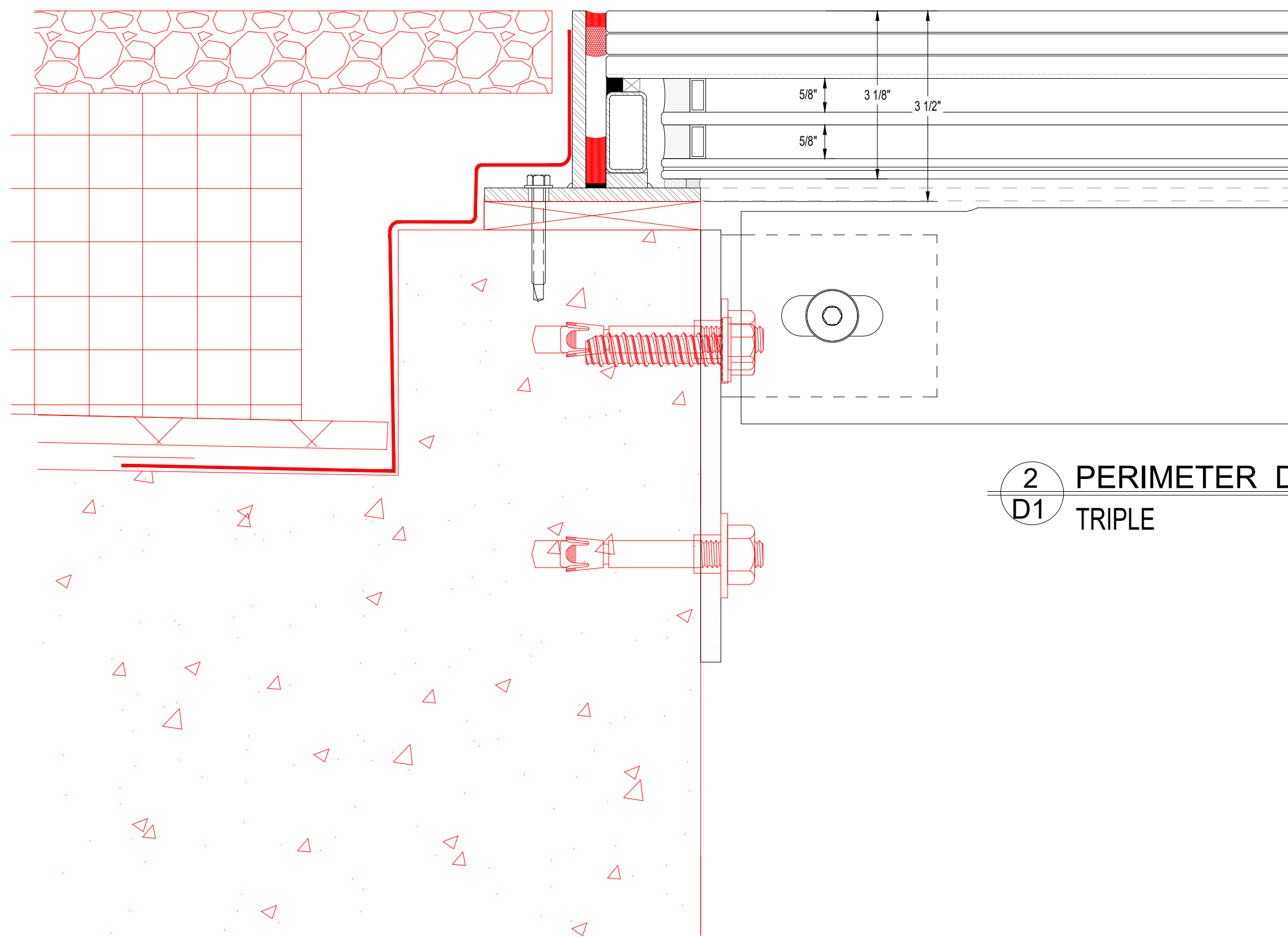
 2 PERIMETER DETAIL
 D1 TRIPLE

TRIPLE-EXTERIOR DETAIL

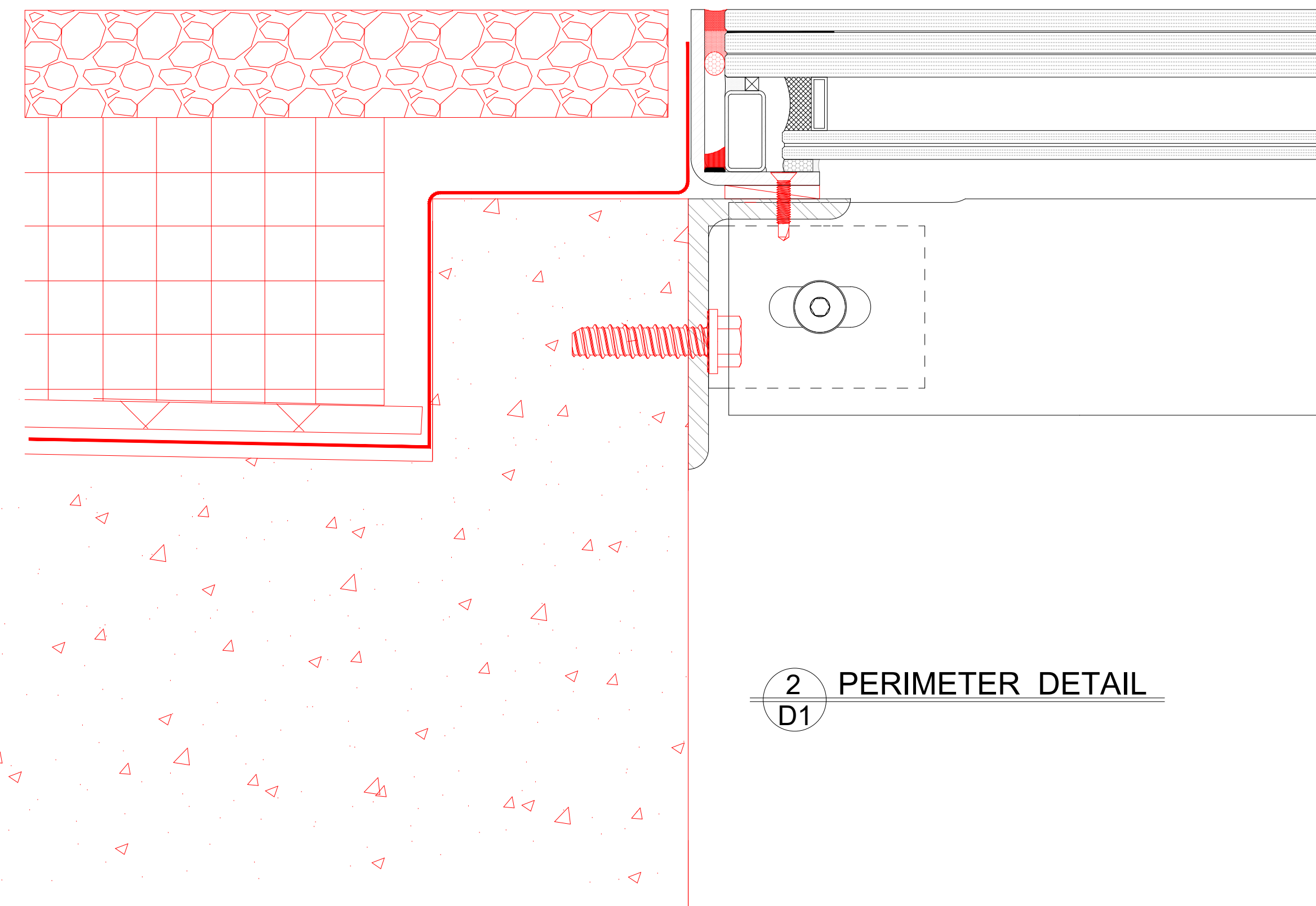
 1 EDGE DETAIL @ CONCRETE
 D1 SCALE: 6" = 10"
 GREENLITE GLASS (INTERIOR DETAILS)

 2 PERIMETER DETAIL
 D1

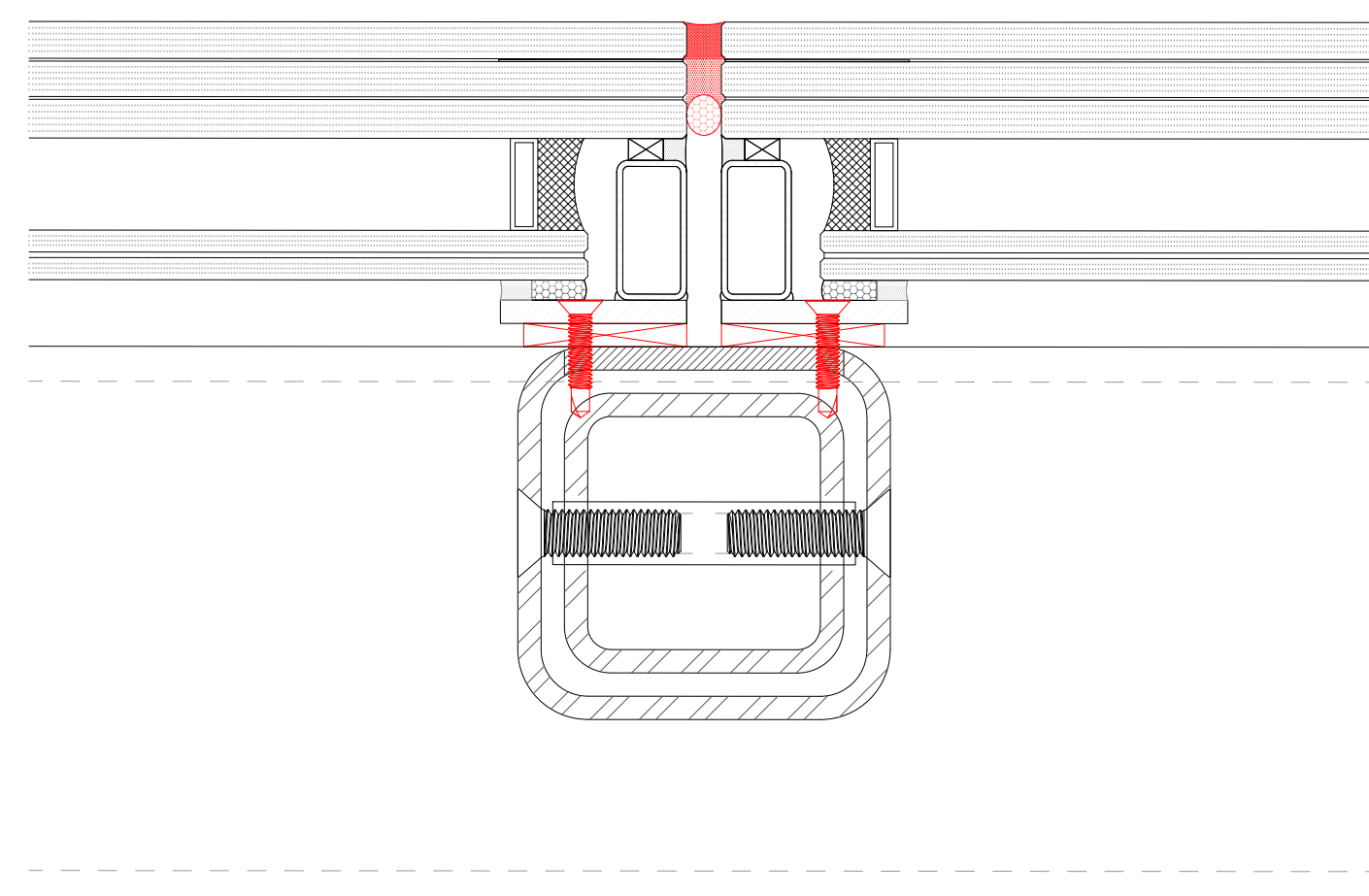
EXTERIOR DETAIL

 2 EDGE DETAIL @ CONCRETE
 D1 SCALE: 6" = 10"
 GREENLITE GLASS (INTERIOR DETAILS)

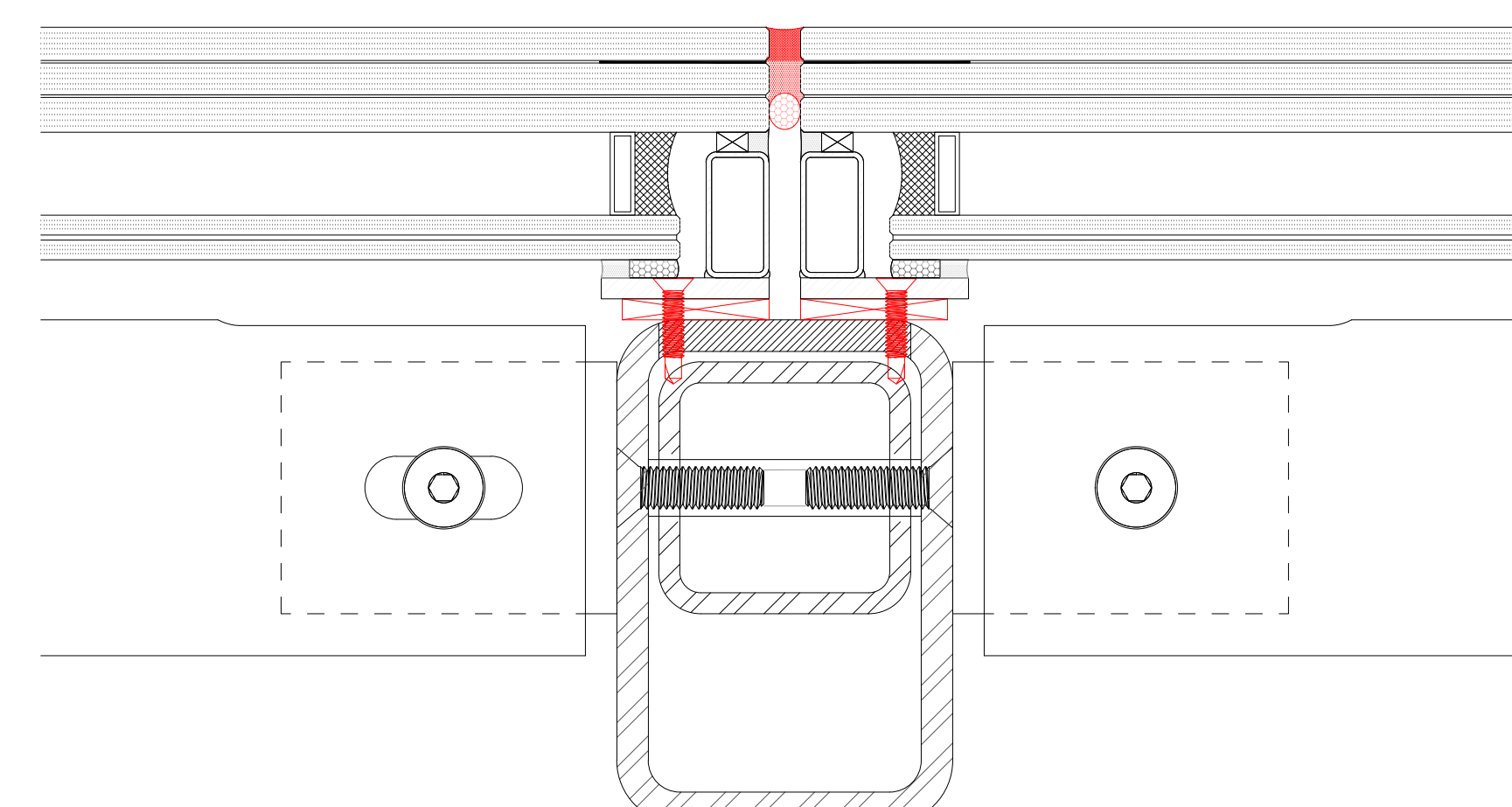
 3 PURLIN DETAIL
 D1

EXTERIOR DETAIL

 3 SECONDARY BEAM CONNECTION
 D1 SCALE: 6" = 10"
 GREENLITE GLASS (INTERIOR DETAILS)

 4 RAFTER DETAIL
 D1

EXTERIOR DETAIL

 4 PRIMARY BEAM CONNECTION
 D1 SCALE: 6" = 10"
 GREENLITE GLASS (INTERIOR DETAILS)